



SCHNECKENLEITNER
AUSTRIA

FASSBINDEREI SCHNECKENLEITNER

1
AUSTRIA



Paul Schneckenleitner working on a Round.

HISTORY

Fassbinderei Schneckenleitner is a fifth generation Austrian artisan family run cooperage that is located in Waidhofen/Ybbs, located in the foothills of the Austrian Alps. The cooperage was founded in 1628 and the Schneckenleitner family has been at the helm of the cooperage since 1880. Schneckenleitner produces premium quality puncheons and large format vessels and they are best known for their ovals and casks or rounds as they call them. The oak for these ovals and rounds (10 HL - 60 HL) are sourced 100% from Austrian Oak. However, the cooperage is also recently offering more Austrian Acacia, especially for aromatic whites.

TODAY

Fassbinderei Schneckenleitner is managed by Paul Schneckenleitner, who is a fifth generation Master Cooper from the Schneckenleitner family. Before managing the family cooperage, Paul gained invaluable experience by working in several Burgundy and Cognac based cooperages.

Schneckenleitner buys entire oak and acacia logs from forests they have been working with for generations. The logs are brought to their production site and the splitting, preparing and air drying of the wood is done on site. They cooper vessels made from tight grain Weidling Oak and Acacia that is sourced from forests in southern Austria.

STYLISTICALLY

Schneckenleitner has built their reputation on the production of their large format ovals and puncheons which are found in many of Europe's finest cellars. Because of the large format, the incredibly long and low toast, and significantly long air-drying time results in extremely low impact ovals, rounds and puncheons that respect the wine's fruit, freshness and minerality, while allowing for some natural micro-oxidation to occur. Their large format vessels work both on white and red wines.



The Schneckenleitner stave mill where logs are received.



The new facade of the cooperage and Paul Schneckenleitner with his sons.



Schneckenleitner casks including 500L 45 mm puncheons.



50 HL conical operating tanks.



Final touches on an Oval.

STRONG POINTS

- Independently family-owned artisanal cooper where all important steps are still done by hand
- Reputation built on 10HL - 60HL+ Ovals and Rounds
- Also coopers 45 mm thick stave puncheons and conicals
- Directly buys and handles logs at stave mill located at the cooperage
- Air drying of oak is done on site
- Selection of 100% Austrian Oak and Austrian Acacia
- Long air drying time for wood preparation
- House toasts are the: AOC (Austrian Oak Complex) and AOE (Austrian Oak Elegance)

2024 SCHNECKENLEITNER USA PRICES

PUNCHEONS

Product	500L WEIDLING	500L ACACIA	600L WEIDLING	600L ACACIA	700L WEIDLING	700L ACACIA	800L WEIDLING	800L ACACIA
29 mm thick Staves	1,885 €	1,829 €	2,210 €	2,144 €	2,635 €	2,556 €	3,045 €	2,954 €
45 mm thick Staves	2,350 €	2,230 €	2,830 €	2,745 €	3,260 €	3,162 €	3,620 €	3,511 €

ROUNDS

Product	LITERS (L)	GALLON (G)	BILGE HEIGHT (IN)	BILGE DIAMETER (IN)	HEAD HEIGHT (IN)	HEAD DIAMETER (IN)	LENGTH OF STAVES (IN)	STAVE THICKNESS (MM)	AUSTRIAN ACACIA	WEIDLING OAK
10HL	1,000	264	49.2	49.2	47	47	51.2	47	11,465 €	11,630 €
13HL	1,300	343	53.5	53.5	47	47	54.7	47	12,985 €	13,195 €
15HL	1,500	396	55.1	55.1	50	50	59.1	50	13,935 €	14,175 €
20HL	2,000	528	60.6	60.6	52	52	63.4	52	16,320 €	16,630 €
25HL	2,500	660	65.7	65.7	57	57	68	57	18,950 €	19,335 €
30HL	3,000	793	69.6	69.6	70	70	72	60	21,275 €	21,745 €

OVALS

10HL	1,000	264	57.8	41.7	53.1	48	51.2	48	11,670 €	11,835 €
12.5HL	1,250	330	61	43.3	56.3	48	53.5	48	12,895 €	13,095 €
15HL	1,500	396	66	46.8	62.2	50	55.5	50	14,200 €	14,440 €
20HL	2,000	528	74	50.7	68.9	53	60.2	53	16,790 €	17,105 €
25HL	2,500	660	80.3	56.3	74.4	55	62.2	55	19,235 €	19,620 €
30HL	3,000	793	84.3	58.3	78	57	67.7	57	21,835 €	22,305 €

OVAL WITH STANDARD ACCESSORIES

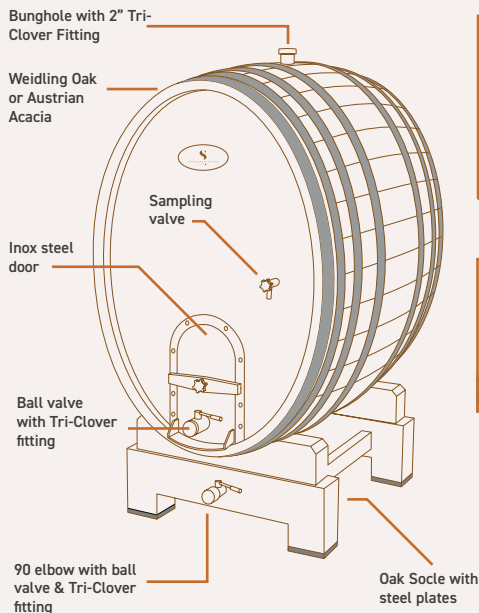

- Oval vertical/horizontal door available upon request.
- Partial or full discharge valves, sample port and manhole available on 5, 6, 7 or 8 HL casks. Available on request.
- Additional sizes up to 60HL available on request, as well as conical upright tanks for aging and maturation.

CASK & OVAL OPTIONS

500L - 800L OPTIONS

Outlet Connection 1" with Cap	143 €
2" Tri Clover racking ball valve on head	293 €
90 degree elbow drain with 2" Tri Clover butterfly valve	756 €
Wooden Socle	510 €

10HL - 60HL OPTIONS

Top Manhole with TC fitting and pressure compensating valve	Varies on size
Painted Hoops	Varies on size
Cooling Plate	Varies on size
Colmatore	188 €
Laser Engraving	435 €
Thermometer with immersion sleeve	390 €
Thermowell	225 €
1x Oak Support Bar on Head	595 €
2x Oak Support Bar on Head	1050 €

WOOD SELECTIONS

- Weidling Oak**
Selection of fine grain oak from a forest in Southern Austria.
- Austrian Acacia**
Selection of Acacia sourced from Southern Austria.

TOAST LEVELS

- Intended for whites or light reds.
AOE - / AOE / AOE+
- Intended for rich whites or bold reds.
AOC - / AOC / AOC+

15



SCHNECKENLEITNER
AUSTRIA